



PSB Industries Inc.

General Air Division

Pneumatically Operated Zero Loss Drain

- 250 PSIG Standard
- See Through Vessel
- Fully Pneumatic
- Zero Wasted Air
- No Electricity Required
- Extremely Low Profile
- Non Clogging Ball Valve
- Normally Closed Ball Valve
- No Strainers to Clean
- Exclusive Valve Stem Support System
- Automatic Operation
- Manual Override Test Button



PZLD Technical Data	
PSB Model / Part Number	PZLD / 71034-304
Inlet Connection	(2) 3/4" NPT
Outlet Connection	1/2" NPT
Control Air Pressure	80 to 130 psig
Operating Pressure range	0 to 250 psig
Operating Temperature	32 to 180°F
Dimensions, l x w x h (approx)	13" x 9" x 9"
Shipping Weight	16 lbs.
Condensate removed per cycle	24 ounces
Materials of Construction	
Reservoir	Aluminum and Composite
Ball Valve	Bronze body, SS trim
Float and Seat	Stainless Steel
Seal	Viton
Price, USD	\$ 670
Adder for all SS ball valve	\$ 74

PSB INDUSTRIES INC.

General Air Division

1202 West 12th Street • Erie, PA. USA

Phone: 814-453-3651 • Fax: 814-454-3492

www.PSBINDUSTRIES.com

DESIGN

The **PZLD** is the ultimate demand operated drain. The unit is fully automatic, no electricity is required. Its low profile gives you the advantage of installing it in areas where the vessel to be drained is only a few inches from the ground. The **PZLD's** design also eliminates the need for the installation of a vent line for most applications. A unique air valve design uses a magnetic force to ensure both a positive opening and closing that will prevent any air loss. The magnetic force is cleverly positioned away from the condensation level to prevent any attraction of metal particulate. An innovative ball valve support and positioning system prevents the side-loading problem which otherwise would cause premature sealing failure around the valve stem. Rifle drilled discharge porting ensures that scale and rust will exit through a full ported 1/2" ball valve. The **PZLD** will not clog ---- no strainer required.

OPERATION

Condensation enters through one of two ports. The see through vessel allows visual inspection of the condensation as it rises. A stainless steel float rises with the level of condensation and positions a magnetic force over the valve housing. When the liquid level reaches the desired level, the magnet in the valve housing snaps upward and allows air to pass through a stainless steel seat. The air then moves to a non-lubricated air cylinder causing it to extend and open the ball valve. Condensation, scale and rust particles rapidly exit the unit. Before any air is lost, the float removes the magnetic force from the valve and the seat is covered with a Viton seal. A powerful spring returns the air cylinder to its normal position and rotates the positive closing ball valve back to its normally closed position. The pilot air used to actuate the air cylinder is isolated from the air in the drain's reservoir.

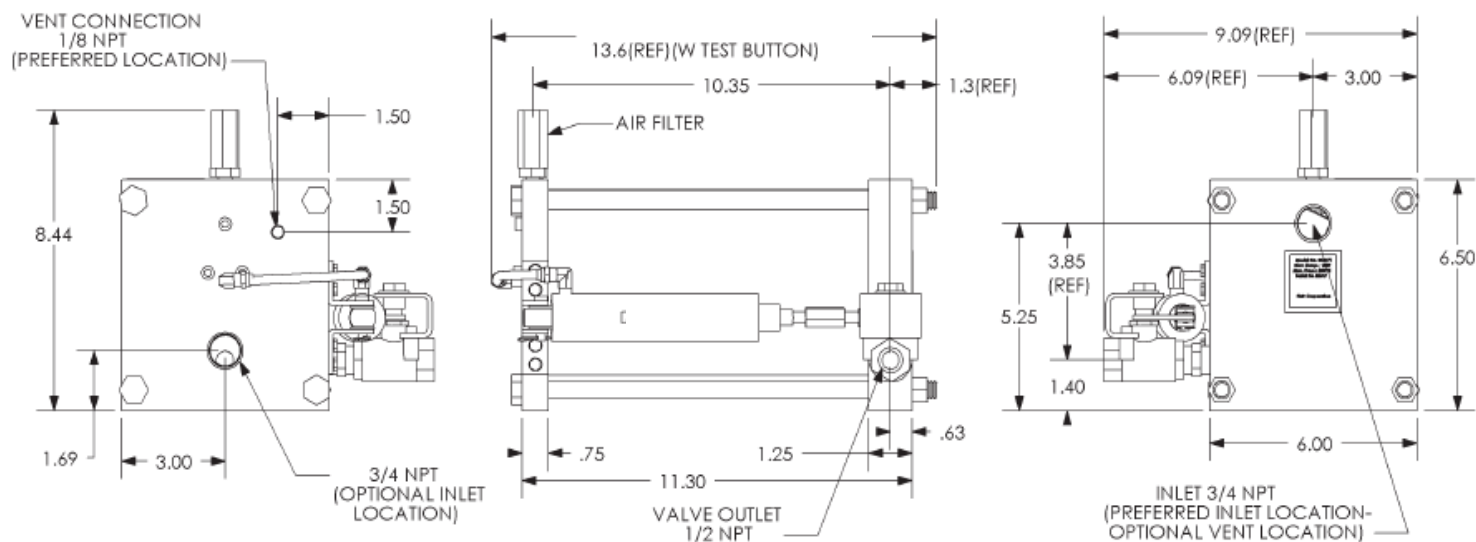

SPECIFICATIONS

Inlets: (2) 3/4" NPT

Outlet: 1/2" NPT

Power: Clean, Dry Compressed Air 80 to 130 PSI

Pressure: 0 to 250 PSI

Operating Temperature: 32° to 180° F.

Weight: 16 lbs.

Discharge: 24 Ounces per cycle.

MATERIALS

Reservoir: Aluminum and Composite

Valve: Bronze w/SS. Ball and Stem

Float: Stainless Steel

Seat: Stainless Steel

Seal: Viton

OPTIONS- Consult factory



PSB INDUSTRIES INC.

General Air Division

1202 West 12th Street • Erie, PA. USA

Phone: 814-453-3651 • Fax: 814-454-3492

www.PSBINDUSTRIES.com

PZLD-03